

ANALYSIS OF THE STABILIZING EFFECT OF ROM ON THE GENETIC NETWORK CONTROLLING *COIE1* PLASMID REPLICATION

P. J. E. GOSS

MCZ Laboratory, Department of Organismic and Evolutionary Biology, Harvard University, 26 Oxford Street, Cambridge MA 02138 (USA) goss@mcz.harvard.edu

J. PECCOUD

TIMC-IMAG, Faculte de Medecine de Grenoble, 38706 La Tronche Cedex (France)^a

A stochastic model of *CoIE1* plasmid replication is presented. It is implemented by using UltraSAN, a simulation tool based on an extension of stochastic Petri nets (SPNs). It allows an exploration of the variation in plasmid number per bacterium, which is not possible using a deterministic model. In particular, the rate at which plasmid-free bacteria arise during bacterial division is explored in some detail since spontaneous plasmid loss is a widely observed empirical phenomenon. The rate of spontaneous plasmid loss provides an evolutionary explanation for the maintainance of Rom protein. The presence of Rom acts to reduce variance in plasmid copy number, thereby reducing the rate of plasmid loss at bacterial division. The ability of stochastic models to link biochemical function with evolutionary considerations is discussed.

1 Introduction

Many systems of plasmid copy number control have been extensively studied, because of the role of plasmids in the spread of antibiotic resistance and because of the experimental utility of plasmids in molecular biology and biotechnology^{1,2,3}.

A number of quantitative models of plasmid copy number control have been published⁴. Plasmid *CoIE1* has been a particular focus for modeling^{5,6,7,8,9,10,11,12}. *CoIE1* replication is an attractive system to model because the molecular basis for replication control is well-characterized, and because most synthetic cloning vectors are derived from *CoIE1*-like plasmids. Merlin and Polisky¹³ give a review of quantitative models of *CoIE1*. Ehrenberg¹² provides a detailed comparison of the models of Brenner and Tomizawa¹⁰ and Brendel and Perelson¹¹, with a particular focus on the differences between multiple step and single step inhibition reactions in replication control.

^aCorresponding author. Current address: Genomation Laboratory, Department of Electrical Engineering, University of Washington, Box 352500, Seattle WA 98195 (USA) jpeccoud@ee.washington.edu

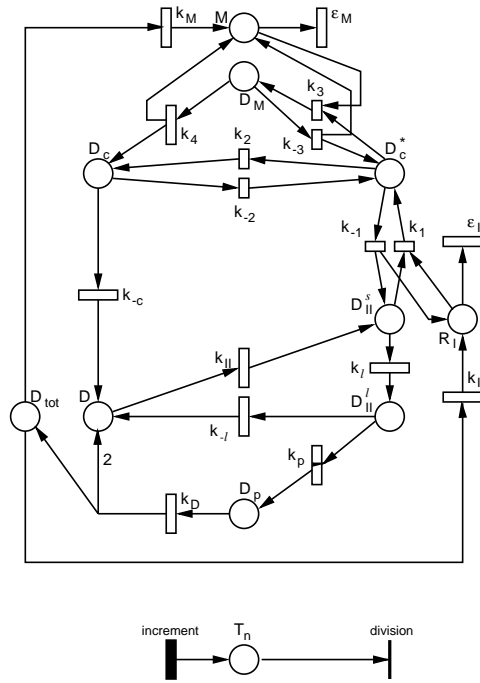

Figure 1: SPN subnet plasmid replication.

The timing of *ColE1* replication is random¹⁴, and, in the absence of evidence to the contrary, *ColE1* segregation at bacterial division is assumed to be random³. Ignoring the effects of Colicin production, stability of *ColE1*-type plasmids requires that the number of plasmids per bacterium is sufficiently high to render the probability of one daughter cell not inheriting any copies of the plasmid negligible. With 20 copies of a plasmid segregating randomly at bacterial division, the probability one daughter cell inheriting zero plasmids is less than 10^{-6} . However, the exact number of plasmids in each bacterium prior to division will vary, both because of random segregation and because of the random timing of plasmid replication events. Variance in plasmid number per bacterium increases the probability of plasmid-free lineages³.

We present a stochastic model of *ColE1* replication, based upon a deterministic model by Brendel and Perelson¹¹. With around 30 copies per bacterium, the assumption of mass action required for a deterministic model is not satisfied, and a stochastic model provides a more precise representation

of plasmid replication¹⁵. A major advantage of this stochastic model is that it rules the dynamics of the statistical distribution of the plasmid copy number per bacterium, thus providing the possibility to compute the rate at which plasmid-free lineages arise.

Rom is not an essential part of the *ColE1* control mechanism. Rom-minus mutants of *ColE1* are observed to occur, and have increased copy number¹⁶. Increased plasmid copy number tends to increase the metabolic cost to the host, but this is not a sufficient explanation for the maintenance of Rom protein, since changes in other parameter values could also lower mean plasmid copy number. We present evidence that Rom has a role in canalizing mean plasmid copy number, with wildtype plasmids having a lower variance in plasmid number than Rom-minus plasmids for a given mean, and thereby a lower probability of loss due to random segregation.

We review briefly the mechanism of *ColE1* replication following the notation of previous papers^{11,15}. Three different plasmid products are involved in the regulation of plasmid replication, RNA I and RNA II, and Rom protein. RNA II (R_{II}) is transcribed from free plasmid (D) and remains bound to the plasmid during transcription. Once RNA II is released, it is assumed to be degraded and plays no further role in the control of replication. RNA I (R_I) and Rom protein (M) are also produced by free plasmid, but are assumed to diffuse freely in the cytoplasm. While RNA II is between 110 and 360 nucleotides long, free RNA I can hybridize with the plasmid-bound RNA II transcript D_{II}^s to form an unstable complex D_c^* . RNA II transcripts that escape interaction with RNA I and elongate past 360 nucleotides, D_{II}^l , are either released without replication or prime the plasmid DNA for replication, after which they are released. Unstable complex D_c^* can convert to a stable RNA I-RNA II complex D_c . The RNA I-RNA II complex dissociates from the plasmid DNA and is degraded. Rom protein can bind to unstable complex D_c^* to form an intermediate complex D_M which rapidly converts to stable complex D_c . Overall, the binding of RNA I molecules to short RNA II transcripts acts as a negative feedback loop to prevent runaway replication of plasmids. Rom protein has a role in reinforcing this negative feedback, but has no effect in the absence of RNA I. The growth rate of bacteria is assumed to be constant, and the decrease in concentration of different molecular species as the volume of the cell increases is represented in the differential equations by μ , the rate of increase of cytoplasmic volume.

SPNs are a formalism developed in the field of Computer Science for implementing a subset of Markov processes, and have a standard graphical representation¹⁷. The validity of using SPNs to model the dynamics of molecular interactions at low concentration was established previously¹⁵. We used the

software package named UltraSAN to analyze the models presented in this paper¹⁸.

2 Methods

The subnet representing the plasmid replication used in this paper is almost identical to the one introduced previously¹⁵ except that an additional place D_{tot} is introduced to track the total number of plasmids. Output measures are defined to give the mean, variance and distribution of the total number of plasmids, the number of free RNA I molecules and the number of free Rom proteins. The results are reported at fixed intervals during each bacterial generation. The distribution of the number of plasmids per bacterium immediately before division can be used to estimate the probability of a plasmid-free daughter cell arising. Time-averaged results are also reported, where the average of mean copy number over one generation represents the average copy number that would be observed in an asynchronous population of bacteria. Rom-minus mutants are represented by a subnet where the places M and D_M and the transitions k_M , ε_M , c_3 , k_{-3} , and k_4 are removed.

Bacteria are assumed to grow exponentially with a fixed doubling time T_D , set at either 80 minutes or 30 minutes. Exponential growth is approximated in the model by dividing each generation into 100 equal time steps. Increasing the number of time steps does not affect the results (data not shown). A deterministic transition is used to increment a time counter at fixed time intervals. The rate constants of the two second-order reactions are functions of the time counter. If n is the value of the time counter at time t_n , and $c(0)$ is the initial reaction rate, the time dependent rate constant $c(t_n)$ is given by $c(t_n) = c(0) e^{-\ln(2) \frac{n}{100}}$.

When the time counter reaches 100, bacterial division is initiated. By assumption, division occurs instantaneously. Division is implemented in the model by an instantaneous transition which fires once T_n reaches 100, and resets T_n to zero (in effect resetting the volume of the daughter cells to the initial volume $V(0)$). The other functions which need to be performed at bacterial division, dividing the number of plasmids, RNA I molecules and Rom proteins, are performed in a second subnet linked to the first one by the composed model editor. Details of the implementation will be presented elsewhere. The model used to produce the results of this paper can be downloaded over the net (<http://www-timc.imag.fr/spns/>).

Plasmid-free lineages are defined as bacteria which have zero plasmids. The output measures defined above do not distinguish between lineages still containing plasmids and plasmid-free lineages. In order to compare means

and variances across simulations, it is useful to report means and variances as conditional on the lineage still containing plasmids. Given the number of runs, N , the number of plasmid-free lineages, n_\emptyset , and the mean and variance of the number of plasmids, \bar{X}_D and s_D^2 , the conditional means and variances, \bar{X}_D^* and s_D^{2*} are calculated as follows: $\bar{X}_D^* = \frac{N}{N-n_\emptyset} \bar{X}_D$ and $s_D^{2*} = \frac{1}{n_\emptyset-1} \left[(N-1)s_D^2 + N(\bar{X}_D)^2 - n_\emptyset(\bar{X}_D^*)^2 \right]$. The conditional means and variances of the numbers of RNA I molecules and Rom proteins are calculated similarly, with the additional assumption that the number of RNA I molecules and Rom proteins in plasmid-free lineages is zero.

Immediately before bacterial division, the distribution of the number of plasmids per bacterium is approximately normal. Simulations report the mean and variance of this distribution. In each bacterium the plasmids are segregated randomly between the two daughter cells. Given n plasmids in a bacterium, the probability of one daughter cell inheriting zero plasmids is $2 \cdot 0.5^n = 0.5^{n-1}$.

If plasmids are normally distributed with an observed mean \bar{X} and variance s^2 , then the probability of at least one plasmid-free lineage after bacterial division can be approximated by integrating the product of the probability density function and the probability of a plasmid-free lineage for a given n . The integral is taken from 1 to infinity, because we are interested in the probability of a plasmid-free lineage conditional on the parent lineage containing at least one plasmid. This integral is

$$Pr(\text{plasmid free lineage}) = \int_1^\infty 0.5^{x-1} N_{\mu, \sigma^2}(x) dx \quad (1)$$

where $N_{\mu, \sigma^2}(x)$ is the probability distribution function for a normal distribution with mean μ and variance σ^2 . Eq. 1 can be integrated numerically.

Plasmid number per bacterium is a discrete rather than continuous variable, so the approximation of the plasmid distribution by a normal distribution may not be justified. When the probability of plasmid-free lineages arising is calculated as the sum over a discrete distribution, the results are very similar to the results given by the integral in Eq. 1 (data not shown). The integral is used rather than the discrete sum because it is easier to calculate.

3 Results

To simulate the establishment of a plasmid which has newly invaded a bacterium, stochastic simulation runs are started with a single plasmid, and no RNA I or Rom protein. The distribution of plasmid number per bacterium is measured every 20 minutes when the generation time is 80 minutes, and

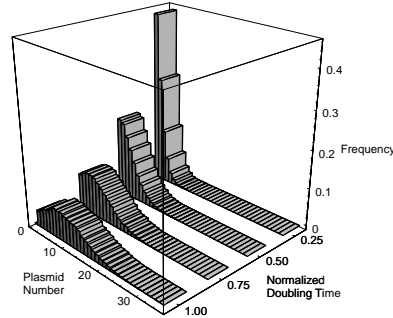

Figure 2: Distribution of plasmid number during the first 30 minute generation.

Table 1: Within generation trajectory of plasmid mean (SD), equal or binomial segregation. Wildtype plasmid number from generation 10, 80 minute generation time, based on 1000 runs of simulation.

Time after last bacterial division	Binomial		Equal	
	Mean	(SD)	Mean	(SD)
0 min	19.3	(4.1)	19.5	(2.6)
20 min	22.8	(4.6)	23.0	(3.1)
40 min	27.0	(4.9)	27.2	(3.7)
60 min	32.1	(5.3)	32.2	(4.4)
80 min	38.2	(5.8)	38.2	(5.0)

every 7.5 minutes when the generation time is 30 minutes. The change in the distribution of plasmid number through the first generation is shown in Fig. 3.

The dynamics of plasmid replication is studied under the assumptions of equal segregation or binomial segregation of plasmids at bacterial division. Binomial segregation represents an additional source of variance, but is assumed to be the actual mode of segregation for *ColE1*. Standard deviation of copy numbers is decreased under the assumption of equal segregation, although mean copy number is indistinguishable under the two assumptions ($t = 0.55$, $P > 0.5$). While standard deviation of plasmid number is decreased under equal segregation, especially immediately after bacterial division, it increases more during each generation (Table 1). The rest of the results reported in this paper use the assumption of binomial segregation.

By generation 10 the system has reached a periodic steady state, where

mean plasmid number doubles during each bacterial generation before being divided between the two daughter cells at bacterial division. The probability of loss of plasmids is very low once plasmid copy number has reached periodic steady state. Even with a 30 minute generation time, plasmid loss is only observed in simulations in the first few generations after a plasmid invades a bacterium (Table 2). When bacteria are started with 100 plasmids, no cases of plasmid loss are seen. Given the mean and variance of plasmid number immediately before bacterial division, it is possible to estimate the probability of plasmid loss per bacterium per generation using Eq. (1). Table 3 gives the steady state mean and variance of plasmid number immediately before bacterial division, as well as the predicted rate of plasmid loss.

To test the effect of Rom protein on the rate of plasmid loss, simulations are run for a Rom-minus plasmid with RNA II synthesis rate, k_{II} decreased from 0.25 min^{-1} to 0.18 min^{-1} . Given a 30 minute bacterial generation time, mean plasmid number is 21.3 for this modified Rom-minus plasmid (conditional on the presence of plasmids), compared to 20.9 for a wildtype plasmid. Simulations are run starting with 1 or 10 plasmids per bacterium, where a bacterium started with 10 plasmids is close to steady state. When the simulations are started with 1 plasmid per bacterium, 58 plasmid-free lineages are observed for wildtype plasmids, and 113 plasmid-free lineages for Rom-minus plasmids ($P < 0.001$). When bacteria are started with 10 plasmids, the rate of plasmid loss is very low. In order to estimate the rate of plasmid loss more precisely, the simulation is run 50,000 times. After 10 generations, 6 plasmid-free lineages are observed for the Rom-minus plasmid, a rate plasmid loss of $1.2 * 10^{-5}$ per bacterium per generation. Only one of the two daughter cells is observed, so the expected value for the true rate of loss of plasmids is $2.4 * 10^{-5}$ per bacterium per generation.

Table 2: Loss of plasmids and average plasmid number (30 minute generation time). N_{\emptyset} , observed frequency of plasmid-free lineages in 1000 runs of simulation. Plasmid mean is time-averaged over each generation, conditional on presence of plasmids.

Generation	Wildtype		Rom-minus	
	N_{\emptyset}	Mean	N_{\emptyset}	Mean
1	0	4.1	0	4.2
2	45	10.1	51	11.8
3	52	14.6	56	19.1
4	54	17.3	56	24.7
5	55	18.8	56	28.2
10	55	20.7	56	33.7

Table 3: Predicted probability of plasmid loss in steady state. Plasmid mean (standard deviation) immediately before bacterial division at end of generation 10, conditional on presence of plasmids, based on 1000 runs of simulation. $\text{Pr}(\text{loss})$, predicted probability of plasmid loss for given mean and standard deviation, from Eq. 1. $\text{Pr}(\text{loss} / \text{no variance})$, predicted probability of plasmid loss for given mean and zero variance, as for a deterministic model.

Generation Time	Mean	(SD)	$\text{Pr}(\text{loss})$	$\text{Pr}(\text{loss} / \text{no variance})$
<i>Wildtype plasmid</i>				
80 minute	38.3	(5.8)	$1.9 * 10^{-8}$	$5.9 * 10^{-12}$
30 minute	29.1	(5.7)	$7.7 * 10^{-6}$	$3.5 * 10^{-9}$
<i>Rom-minus plasmid</i>				
80 minute	68.8	(11.5)	$5.0 * 10^{-9}$	$3.9 * 10^{-21}$
30 minute	47.3	(8.8)	$2.6 * 10^{-7}$	$1.2 * 10^{-14}$

Table 4: Predicted probability of plasmid-loss for wildtype and modified Rom-minus plasmids. Mean and standard deviation of plasmid number immediately before bacterial division at generation 10, conditional on presence of plasmids. P_\emptyset , predicted probability of plasmid loss from Eq. 1.

Parameter (min^{-1})	Mean	(SD)	P_\emptyset
WT	28.8	(6.0)	$1.7 * 10^{-5}$
$k_{II} = 0.18$	28.5	(6.9)	$1.1 * 10^{-4}$
$k_l = 7.5$	28.9	(6.5)	$4.4 * 10^{-5}$
$k_{-l} = 8.0$	28.6	(6.9)	$1.1 * 10^{-4}$
$k_p = 2.35$	29.0	(7.1)	$1.2 * 10^{-4}$
$k_I = 9.5$	28.9	(6.5)	$4.2 * 10^{-5}$
$\epsilon_1 = 0.21$	28.9	(6.8)	$6.9 * 10^{-5}$
$c_1(t) = 0.45$	29.1	(6.5)	$4.1 * 10^{-5}$
$k_{-1} = 13.0$	28.7	(6.4)	$3.8 * 10^{-5}$
$k_2 = 150$	29.2	(6.5)	$3.8 * 10^{-5}$

Given the mean and standard deviation of plasmid number immediately before division, probability of plasmid loss can be estimated using Eq. 1. Modified Rom-minus plasmid strains are defined by varying individual parameters so that mean plasmid number is equal to wildtype mean plasmid number. Nine parameters are sufficiently correlated with plasmid number to allow modified Rom-minus strains to be defined. Table 4 gives the predicted probability of loss for a wildtype plasmid and for the nine modified Rom-minus plasmid strains. For each modified Rom-minus plasmid, standard deviation of plasmid number is higher than for the wildtype plasmid, even though mean plasmid numbers are very close. The predicted rate of plasmid loss is between 2-fold and 7-fold higher for the modified Rom-minus plasmids than for the wildtype plasmid.

4 Discussion

Given that the *ColE1* plasmid replication system has been modeled deterministically several times^{5,6,7,8,9,10,11,12}, what do we learn from a stochastic model? We argued that a stochastic model has a stronger theoretical justification than a deterministic model¹⁵ given that mean plasmid number per bacterium is small. The mean number of plasmids, RNA I transcripts and Rom proteins is very similar in both the deterministic model of Brendel and Perelson¹¹ and the stochastic model presented here (data not shown). Put another way, the plasmid copy number of the deterministic model provides a good approximation to the time-averaged mean copy number of the stochastic model, even though the assumption of mass action is not met.

One important practical difference between the models is that the stochastic model rules the dynamics of the distribution of probability of plasmid number per bacterium, while the deterministic model rules the dynamics of a single state. It is still difficult to measure the distribution of plasmids in individual bacteria directly. However, the variation in plasmid number affects the probability of plasmid loss, and it may be possible to estimate the rate of plasmid-loss empirically. The probability of plasmid loss, which depends on the distribution of plasmid number immediately before bacterial division, is four orders of magnitude higher for the stochastic model than for the deterministic model relying only on a stochastic mechanism of plasmid segregation.

Boe *et al.*¹⁹ discuss the rate at which plasmid-free lineages spread through the population, based on a given frequency of plasmid loss and various differences in growth rate between bacteria with or without plasmids. However, we do not need a theoretical treatment to convince us of the significance of the differences between the deterministic and stochastic models if we convert these probabilities into expected waiting times until a plasmid-free lineage arises. Let us assume 80 minute bacterial generation time, and a 10ml test tube with 10^9 bacteria per ml. If the probability of loss is $4.5 * 10^{-12}$, as for the deterministic model, we expect 0.045 plasmid-free lineages to arise per generation. This translates to 1 plasmid-free lineage per 22 generations, or 29.6 hours. If the probability of loss is $1.9 * 10^{-8}$, as for the stochastic model, we expect 190 plasmid-free lineages to arise per generation. It is difficult to test these numbers directly for *ColE1*, because Colicin production would kill plasmid-free bacteria. However, stochastic models of replication control for related plasmids which lack Colicin genes would be very interesting, where the rate of plasmid loss could be empirically observed and compared to the predictions of the model.

What are the effects of structural changes in the replication control mech-

anism? Rom-minus mutants are observed experimentally, and have approximately double the plasmid copy number of wildtype plasmids. However, Rom is not necessary for plasmid replication control, which raises the question of why it is maintained. The comparison of results for a wildtype plasmid with a modified Rom-minus plasmid conducted for bacteria with 30 minute generation time in order to increase the rate of plasmid loss to an observable level, although this rate is still extremely low. A modified Rom-minus plasmid is defined where the rate of RNA II synthesis has been reduced from 0.25 min^{-1} to 0.18 min^{-1} in the Rom-minus strain, so that mean plasmid number is equal to that for a wildtype. This removes any potential metabolic cost to the host of increased plasmid numbers in the Rom-minus strain, and allows for direct comparison of the rate of plasmid loss between the two strains. Rom is assumed to have no function other than its role in *ColE1* plasmid replication control.

Simulations are started with 1 or 10 plasmids, representing plasmid establishment or the periodic steady state. Significantly more plasmid-free lineages are observed for the modified Rom-minus plasmid than for the wildtype during the establishment phase of plasmid replication, but there may be some bias in the pattern of plasmid loss in the first few generations. Bacterial lineages started with 10 plasmids should not be subject to this bias. However, the observed rate of plasmid loss is too low to show significant differences between the plasmid strains, even with 50,000 runs of simulation (which takes 2.25 days for the Rom-minus plasmid on a Pentium 166).

Table 4 gives the mean plasmid number immediately before bacterial division at the end of generation 10 for wildtype and nine modified Rom-minus plasmid strains. Plasmid mean and variance can be used to predict the probability of plasmid loss using Eq. 1. In all cases, the modified Rom-minus plasmids are lost at a higher rate than wildtype plasmids, even though there is no difference in mean plasmid number. Even though the rate of plasmid loss is very low, the increased replication rate of plasmid-free bacteria means that any difference in the rate of plasmid loss in individual bacterial lineages may be sufficient to alter the overall fate of plasmids in a bacterial population¹⁹. Thus, the lower rate of plasmid loss when Rom is present provides an evolutionary explanation for the maintainance of Rom protein.

Bacterial lineages without plasmids can replicate more rapidly than bacterial lineages with plasmids³. Thus, we would expect that the *ColE1* replication system functions to limit the rate of plasmid loss. The rate of plasmid loss depends primarily on mean plasmid number per bacterium, but is also affected by the variation in plasmid number between individual bacteria. Arguments based on metabolic cost suggest that increased plasmid copy number

slows host growth. Plasmid stability involves a trade-off between the probability of plasmid loss and the metabolic cost to the host. A mechanism which reduces variance in copy number without increasing mean plasmid number, in effect canalizing plasmid number against stochastic fluctuations, would increase plasmid stability without increasing the metabolic cost to the host. The results presented here suggest that Rom functions in this manner. Rom-minus plasmids have higher mean plasmid number than do wildtype plasmids, but altering any individual parameter in a modified Rom-minus plasmid, so as to equalize mean plasmid number, causes an increase in the standard deviation of plasmid number and an increased rate of plasmid loss compared to a wildtype. It is impossible to know whether Rom was originally selected for this role in canalizing plasmid number, but these results suggest that Rom is selectively maintained for its canalizing function.

Acknowledgments

We are indebted to Jacques Demongeot, Deirdre Meldrum, Richard Lewontin for their support. JP is supported by INSERM and a fellowship from NATO.

References

1. P. Broda. *Plasmids*. Freeman, San Francisco, CA, (1979).
2. K. G. Hardy. *Plasmids. A Practical Approach*. Oxford University Press, New York, NY, 2nd edition, (1993).
3. D. K. Summers. *The Biology of Plasmids*. Blackwell Science, Oxford, (1996).
4. C. M. Thomas. Recent studies on the control of plasmid replication. *Biochimica et Biophysica Acta*, **949**:253–263 (1988).
5. M. M. Ataai and M. L. Shuler. Mathematical model for the *ColE1* type plasmid replication. *Plasmid*, **16**:204–212 (1986).
6. H. Bremer and S. Lin-Chao. Analysis of the physiological control of replication of *ColE1*-type plasmids. *J. Theor. Biol.*, **123**:453–470 (1986).
7. J. D. Keasling and B. O. Palsson. On the kinetics of plasmid replication. *J. Theor. Biol.*, **136**:487–492 (1989).
8. J. D. Keasling and B. O. Palsson. *ColE1* plasmid replication: A simple kinetic description from a structured model. *J. Theor. Biol.*, **141**:447–461 (1989).
9. B. G. Kim and M. L. Shuler. Analysis of pBR322 replication kinetics and its dependency on growth rate. *Biotechnology and Bioengineering*, **36**:233–242 (1990).

10. M. Brenner and J. Tomizawa. Quantitation of *ColE1*-encoded replication elements. *Proc. Natl. Acad. Sci. U.S.A.*, **88**:405–409 (1991).
11. V. Brendel and A. S. Perelson. Quantitative model of *ColE1* plasmid copy number control. *J. Mol. Biol.*, **229**:860–872 (1993).
12. M. Ehrenberg. Hypothesis: Hypersensitive plasmid copy number control for *ColE1*. *Biophysical Journal*, **70**:135–145 (1996).
13. S. Merlin and B. Polisky. Assessment of quantitative model for plasmid *ColE1* copy number control. *J. Mol. Biol.*, **248**:211–219 (1993).
14. K. Nordström and S. J. Austin. Cell-cycle specific initiation of replication. *Molecular Microbiology*, **10**:457–463 (1993).
15. P. J. Goss and J. Peccoud. Quantitative modeling of stochastic systems in molecular biology using stochastic petri nets. *Proc. Natl. Acad. Sci. U.S.A.*, **95**:6750–6755 (1998).
16. J. Tomizawa and T. Som. Control of *ColE1* plasmid replication: binding of RNA I to RNA II and inhibition of primer formation. *Cell*, **38**:871–878 (1984).
17. M. Ajmone Marsan, G. Balbo, G. Chiola, G. Conte, S. Donatelli, and G. Franceschinis. An introduction to Generalized Stochastic Petri Nets. *Microelectron. Reliab.*, **31**:699–725 (1991).
18. UltraSAN User's Manual, Version 3.0. University of Illinois at Urbana-Champaign.
19. L. Boe, K. Gerdes, and S. Molin. Effects of genes exerting growth inhibition and plasmid stability on plasmid maintainance. *J. Bacteriol.*, **169**:4646–4650 (1987).